

LISTA RICAMBI - SPARE PARTS LIST - LISTA PIEZAS DE REPUESTO



TYPE OF EQUIPMENT

MODEL

MULTIPROCESS WELDING UNIT

FOX 211 DIGITAL 230V

SERIAL NO. FROM H-20-305718	PAGE No. 1 of 2	CODE	99820053	WIRING DIAGRAM	S9820056	PARTS DRAWING	E9820069	DATE	10/09/2021
---------------------------------------	------------------------	-------------	-----------------	--------------------------	-----------------	-------------------------	-----------------	-------------	-------------------

No.	P/N	DESCRIZIONE ARTICOLO	ITEM DESCRIPTION	DESCRIPCIÓN DEL ARTÍCULO	QTY
01	21690226	CHIUSURA A SLITTA + MOLLA X SPESS. 10/10	DOOR LATCH		1
02	05000871	SPORTELO FOX 211 HELVI	ACCESS PANEL FOX 211 HELVI		1
03	04600437	KIT ASPO HELVI C/GHIERA X BOBINE 5 KG	KIT SPOOL HOLDER FOR 5KGS-8" SPOOLS		1
04	21690737	MANOPOLA M1924 X ALB.D.6 CAPP/INDI ROSSO	KNOB M1924		2
05	22735375	SCHEDA REGOLAZ.ESTERNA BBT-SLOPE X FOX	SLOPE EXTERNAL REGULATION PCB		1
06	04600559	KIT BASETTA GAS-NO GAS X TP 220	KIT GAS NO GAS POLARITY BOARD		2
07	21800075	VOLANTINO A CROCE NERO D.40 BOCCOLA M8	BLACK CROSS HANDWHEEL D.40MM M8 BUSHING		2
08	33720380 9005	DIVISORIO FOX 211 NERO	BLACK INTERNAL PANEL FOX 211		1
09	04600381	MOTORE MBT D.40 + PIGNONE OTTONE H=9 MM	MOTOR MBT D.40 + BRASS PINION H=9 MM		1
10	44410066	MOTORID.PLAS./AL SINER. D.40 2R. 0,8-1,0	IRE FEEDER PLAST/AL D.40 2ROLLS 0,8-1,0		1
11	77650647	TARGA FRONTALE FOX 211	FRONT LABEL FOX 211		1
12	04600331	MANOPOLA D.26 X POTENZ. ROSSA + INDICE	RED KNOB D.26 FOR POTENTIOM. + POINTER		1
13	04600332	MANOPOLA D.32 X POTENZ. ROSSA + INDICE	RED KNOB D.32 FOR POTENTIOM. + POINTER		2
14	23005497	CANNETTA GUIDAFILO D.2X5 L=87	WIRE GUIDE TUBE D.2X5MM L=87MM		1
15	23005501	ATTACCO MINIEURO PUNG.L=32 NO CANNETTA	EURO CONNECTION L=32MM GUIDE TUBE L=87		1
16	22100009	PRESA DINSE FISS.PIC.50MMQ TBE35-50 CX58	50SQMM. DINSE SOCKET TBE35-50 CX58		2
17	21690915	GUSCIO ANT. 2 DINSE 50 + FORO AT.EURO	FRONT PLASTIC PANEL		1
18	26075013	SONDA DI CORRENTE YNC-200A =012	HALL PROBE YNC-200A		1
19	22735933	PCB FP MIG+DISP+FULL BRIDGE TP VER	MIG+DISP+FULL BRIDGE FRONT PANEL PCB		1
20	21420011	FERRITE SPACCATA GUSCIO PL. 9X16X29 (C)	TOROID FERRITE 9X16X29		1
21	33700492 9005	FONDO FOX 211 NERO	MIG+DISP+FULL BRIDGE FRONT PANEL PCB		1
22	22735892	MODULO INVERTER 200A NO SONDA (C)	200AMP INVERTER POWER MODULE		1
23	22735897	SCHEDA INTERFACCIA FP MIG DISPLAY - TP	FP MIG DISPLAY - TP INTERFACE PCB		1
24	22205124	COMMUTATORE 17 A A 1702	SWITCH 17A A 1702		1
25	21605010	PRESSACAVALO C/GHIERA "STEAB" X FORO D.20	CABLE CLAMP FOR HOLE D.20		1
26	22910004	RACCORDO PORTATUBO D.6 1/8"M	HOSE TAIL D.6 1/8"M		2
27	22900036	ELETTRORVALVOLA 230V 50/60HZ 9VA 1/8"FF	SOLENOID VALVE 230V 50HZ 9VA 1/8"FF		1
28	20220026	CAVO NEOPR.3X2,5 MT.2,5 SGUAINATO	INPUT CABLE 3X2,5 M.2,5		1
29	04600270	MANOPOLA D.38 X COMMUT. NERA + INDICE	SWITCH KNOB D.38 BLACK		1
30	77601321	ETICHETTA "0-I" X COMMUTATORE FOX 211	0-I SWITCH LABEL		1
31	21690701A	GUSCIO POSTERIORE FOX 170 INT.CON PROT.	BACK FRAME FOX 170/180		1
32	21600076	CINGHIA FERMA CAVO X FOX 211 L=400 H=15	CABLE SECURING BELT L=400 H=15		1
33	22800073	VENTILATORE 120X120X25 DC24V 0,46A 50CM	COOLING FAN 120X120 24VDC+WIRE HARNESS		1

PROPRIETA' ESCLUSIVA & CONFIDENZIALE: questo documento contiene informazioni riservate di proprietà esclusiva di HELVI S.p.A. e non può essere duplicato o inviato a parti terze o usato per altri scopi senza il previo consenso scritto di HELVI S.p.A.

PROPRIÉTÉ EXCLUSIVE ET RÉSERVE: ce document contient des informations réservées de propriété exclusive de HELVI S. p. A. et ne doit pas être photocopié, communiqué à tiers ou utilisé pour autres buts sans l'expresse permission écrite de HELVI. S.p.A.

AUSSCHLIEßENDES EIGENTUM & VERTRAULICHKEIT: dieses Dokument enthält reservierten Informationen, die von ausschließendem Eigentum von HELVI S. p. A. sind. Diese Informationen dürfen nicht reproduziert, zu anderen Parteien mitgeteilt oder für irgendeinen Zweck ohne ausdrückliche geschriebene Erlaubnis von HELVI S.p.A. benutzt werden.

HELVI S.p.A. si riserva il diritto di modificare qualsiasi informazione qui sopra senza preavviso a seguito di possibili migliorie ai propri prodotti. Questo documento, le informazioni qui riportate e/o allegate sono soggetti alle condizioni generali di vendita in vigore con Voi.

En raison des constantes améliorations HELVI S.p.A. se réserve le droit de modifier n'importe quelles informations ci dessus sans notification préalable. Ce document, les informations rapportées et/ou annexées sont assujetties aux conditions générales de vente en vigueur avec Vous.

Auf Grund beständiger Verbesserungen HELVI S. p. A. reserviert das Recht, irgendetwas vom oben ohne vorherige Ankündigung zu ergänzen oder zu ändern. Dieses Dokument, die berichteten bzw. eingeschlossenen Informationen sind abhängig von der allgemeinen Verkaufsbedingungen in Kraft mit Ihnen.

LISTA RICAMBI - SPARE PARTS LIST - LISTA PIEZAS DE REPUESTO

TYPE OF EQUIPMENT

MODEL



MULTIPROCESS WELDING UNIT

FOX 211 DIGITAL 230V

SERIAL NO. FROM H-20-305718	PAGE No.2 of 2	CODE 99820053	WIRING S9820056 DIAGRAM	PARTS E9820069 DRAWING	DATE 10/09/2021
---------------------------------------	-----------------------	----------------------	--	---	------------------------

No.	P/N	DESCRIZIONE ARTICOLO	ITEM DESCRIPTION	DESCRIPCIÓN DEL ARTÍCULO	QTY
34	21600059	MANIGLIA CURVA FOX 170-190 CON GRADINO	CURVED HANDLE WITH STEP		1
35	21690225	CERNIERA PER SPORTELLO IN PLASTICA 20X30	PLASTIC HINGE FOR ACCESS PANEL 20X30		2
36	05000870	MANTELLI DX FOX 211 HELVI	RIGHT COVER PANEL FOX 211 HELVI		1
37	21690702	ASSIEME AGGANCIAMENTO SUPP.CAVO TORCIA FOX170	TORCH CABLE ATTACHMENT SUPPORT		1
38	33805101	RULLINO TRAINAF.D.30 0,8-1,0MM MOT.AL.2R	WIRE FEED ROLL D.30 0,8-1,0MM AL.MOT.2R		1
39	30900030	TUBO POLIPO NERO D.5X10,5 L=2000	BLACK GAS HOSE D.5X10,5 L=2000		1
40	23000350	TORCIA ERGOPLUS 25 MT.3 ATT.EURO MA7243	TORCH ERGOPLUS 25, 3M, EURO CONN. MA7243		1
41	43210132	CAVO DI MASSA 25 MMQ MT.3 CIN.300ZN/DN50	EARTH CABLE 25 MM2 M 3 CL.300A/DN50		1
42	22110033	PINZA DI MASSA IN LAMIERA 300A ZINCATA	EARTH CLAMP 300A		1
43	22100003	SPINOTTO VOLANTE 50MMQ TSK50 CX22	PLUG 50SQMM CX22		2
44	43205098	CAVO SALD. 16 MMQ MT.3 IND.200GHISA/DN50	WELDING CABLE 16MM2 M3 200A EL.HOL./DN50		1
45	22110034	PINZA PORTAELETTRODO 200A INDIA GHISA	ELECTRODE HOLDER 200A		1
46	22905090	RIDUTTORE MINI CO2/ITAL-INGH.2/MAN	GAS REGULATOR MINI CO2/ITAL-UK 2/MAN EC0		1
47	22910014	ADATTATORE PER BOMBOLA CO2-ARGON ITALIA	ADAPTOR FOR CO2-ARGON GAS BOTTLE ITALY		1

PROPRIETA' ESCLUSIVA & CONFIDENZIALE: questo documento contiene informazioni riservate di proprietà esclusiva di HELVI S.p.A. e non può essere duplicato o inviato a parti terze o usato per altri scopi senza il previo consenso scritto di HELVI S.p.A.
PROPRIÉTÉ EXCLUSIVE ET RÉSERVE: ce document contient des informations réservées de propriété exclusive de HELVI S. p. A. et ne doit pas être photocopié, communiqué à tiers ou utilisé pour autres buts sans l'expresse permission écrite de HELVI. S.p.A.
AUSSCHLIEßENDES EIGENTUM & VERTRAULICHKEIT: dieses Dokument enthält reservierten Informationen, die von ausschließendem Eigentum von HELVI S. p. A. sind. Diese Informationen dürfen nicht reproduziert, zu anderen Parteien mitgeteilt oder für irgendeinen Zweck ohne ausdrückliche geschriebene Erlaubnis von HELVI S.p.A. benutzt werden.
HELVI S.p.A. si riserva il diritto di modificare qualsiasi informazione qui sopra senza preavviso a seguito di possibili migliorie ai propri prodotti. Questo documento, le informazioni qui riportate e/o allegate sono soggetti alle condizioni generali di vendita in vigore con Voi.
En raison des constantes améliorations HELVI S.p.A. se réserve le droit de modifier n'importe quelles informations ci dessus sans notification préalable. Ce document, les informations rapportées et/ou annexées sont assujetties aux conditions générales de vente en vigueur avec Vous.
Auf Grund beständiger Verbesserungen HELVI S. p. A. reserviert das Recht, irgendein vom oben ohne vorherige Ankündigung zu ergänzen oder zu ändern. Dieses Dokument, die berichteten bzw. eingeschlossenen Informationen sind abhängig von der allgemeinen Verkaufsbedingungen in Kraft mit Ihnen.

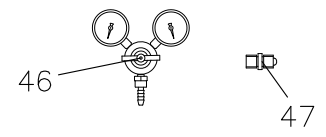
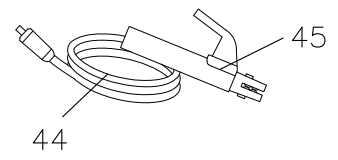
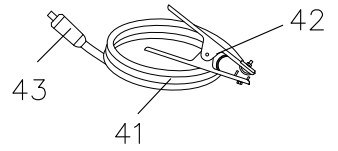
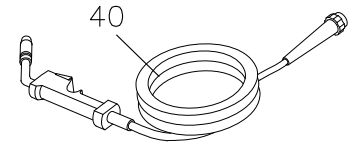
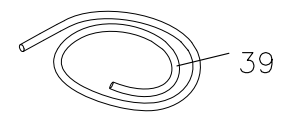
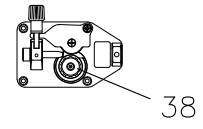
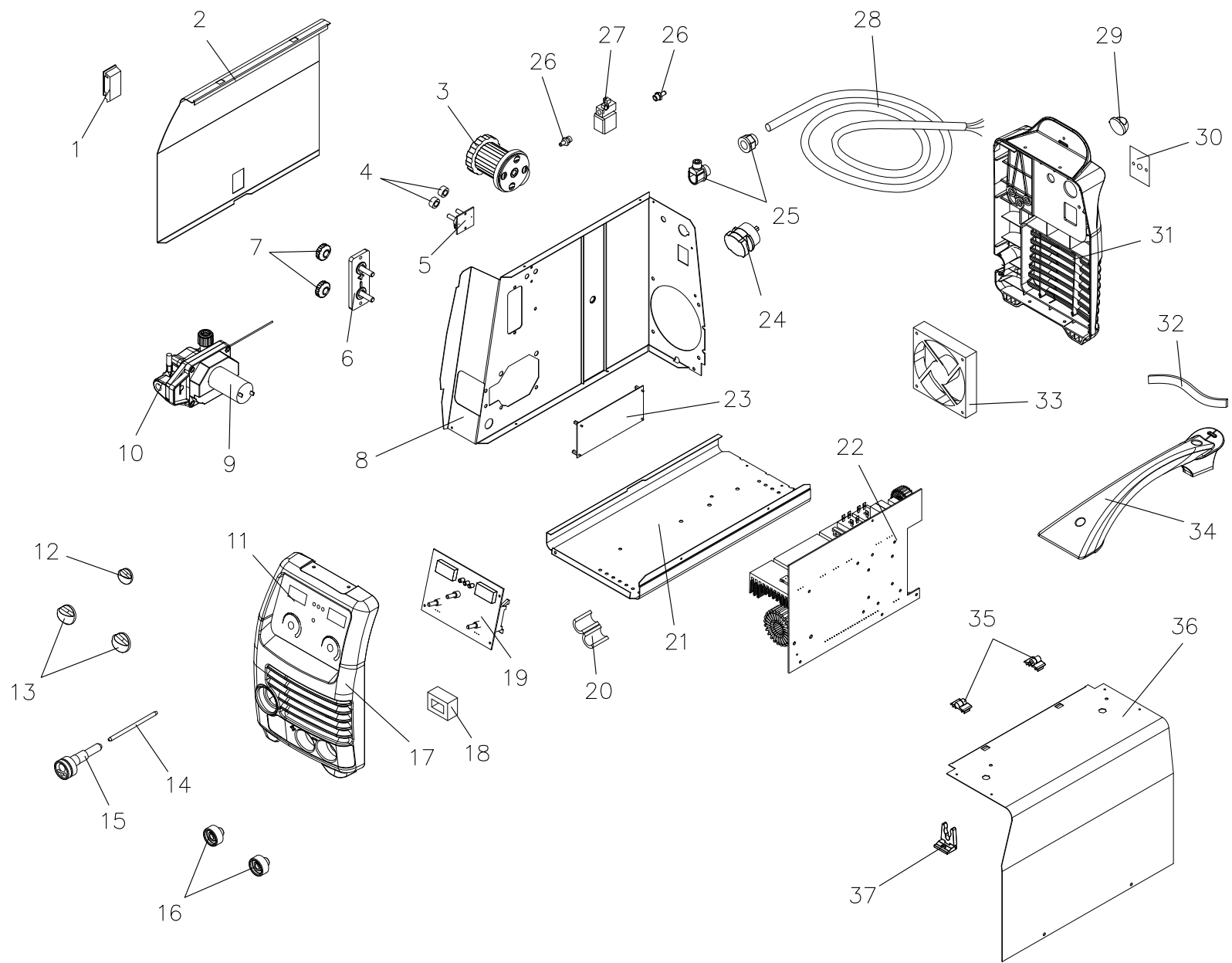

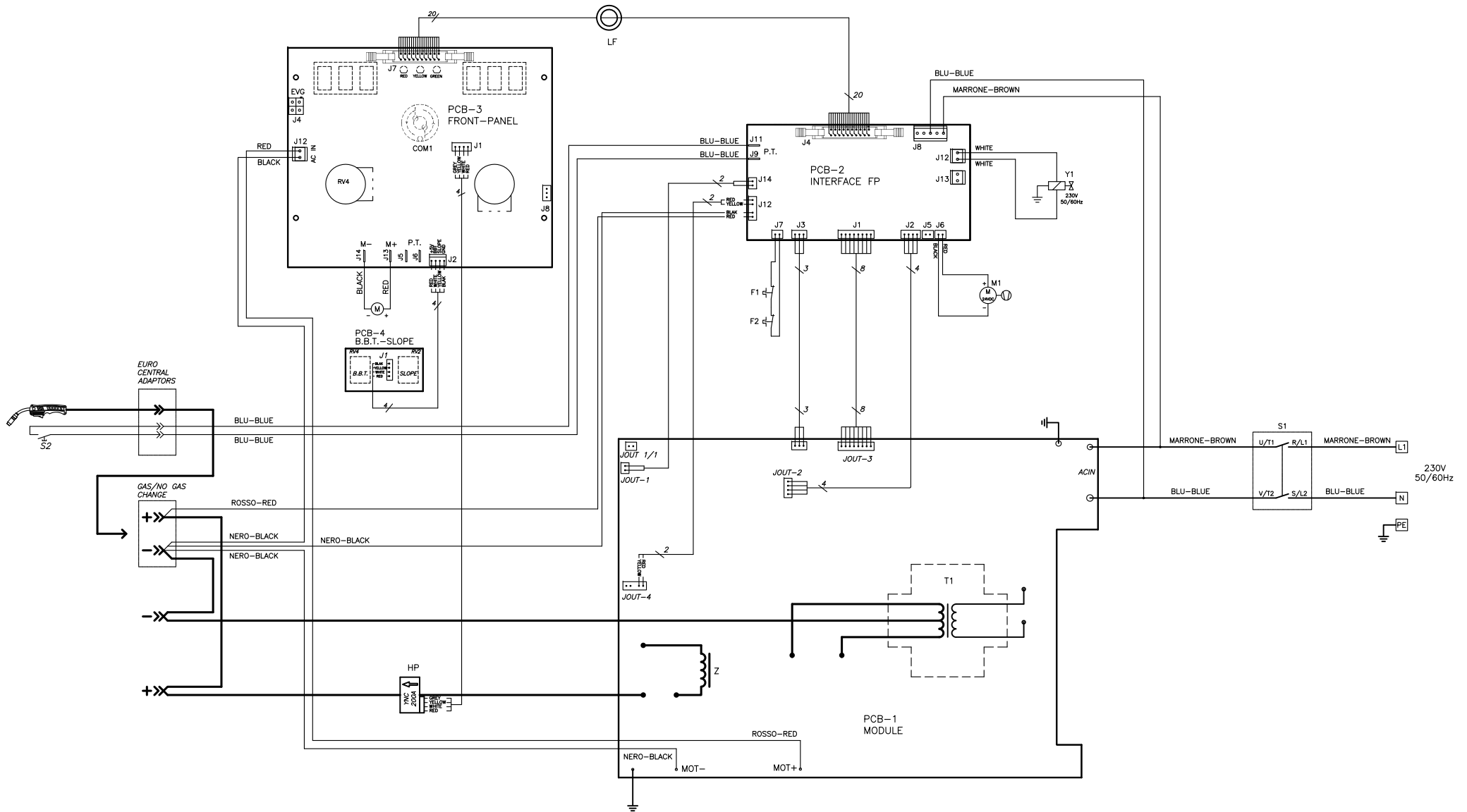

F1-F2	THERMOSTAT	THERMOSTAT	THERMOSTAT	TERMOSTATO	TERMOSTATO
Y1	SOLENOID VALVE	ELEKTROVENTIL	ELETROVANNE	ELECTROVALVULA	ELETTROVALVOLA
M	WIRE FEEDING MOTOR	DRAHTVORSCHUB MOTOR	MOTEUR D'ENTRAÎNEMENT DU FIL	MOTOR ARRASSTRA HILO	MOTORE TRAINA FILO
M1	FAN	VENTILATOR	VENTILATEUR	VENTILADOR	VENTILATORE
PCB 1-4	P.C. BOARD	ELEKTRONIK-PLATTE	FICHE ELECTRONIQUE	CIRCUITO ELECTRONICO	SCHEDA ELETTRONICA
HP	HALL PROBE	STROMSONDE	SONDE DE COURANT	SONDA HALL	SONDA DI CORRENTE

LF	TOROIDAL FERRITE	FERRITRING	FERRITE TOROIDALE	FERRITA TOROIDAL	FERRITE TOROIDALE
S1	ON - OFF	EIN-AUS	ON - OFF	INTERRUPTOR ON - OFF	ON - OFF
S2	TORCH TRIGGER	BRENNER SCHALTER	BOUTON TORCHE	PULSADOR DE LA ANTORCHA	PULSANTE TORCIA
T1	TRANSFORMER	TRANSFORMATOR	TRANSFORMATEUR	TRANSFORMADOR	TRASFORMATORE
Z	CHOKE	IMPEDANZ	IMPEDANCE	IMPEDANCIA	IMPEDENZA

Denominazione

FOX 211

Codice

S9820056