

GALILEO 219
E9805163

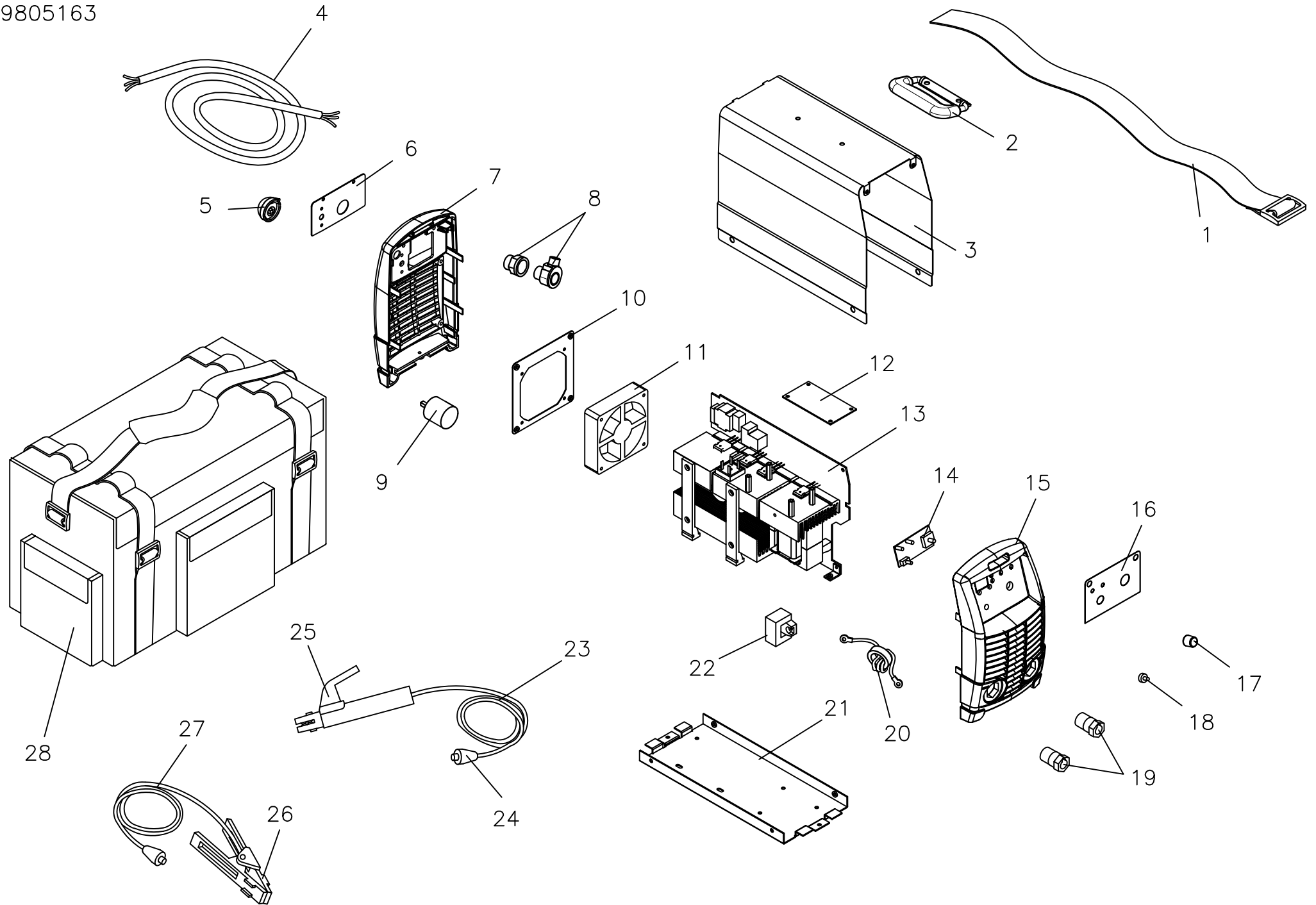

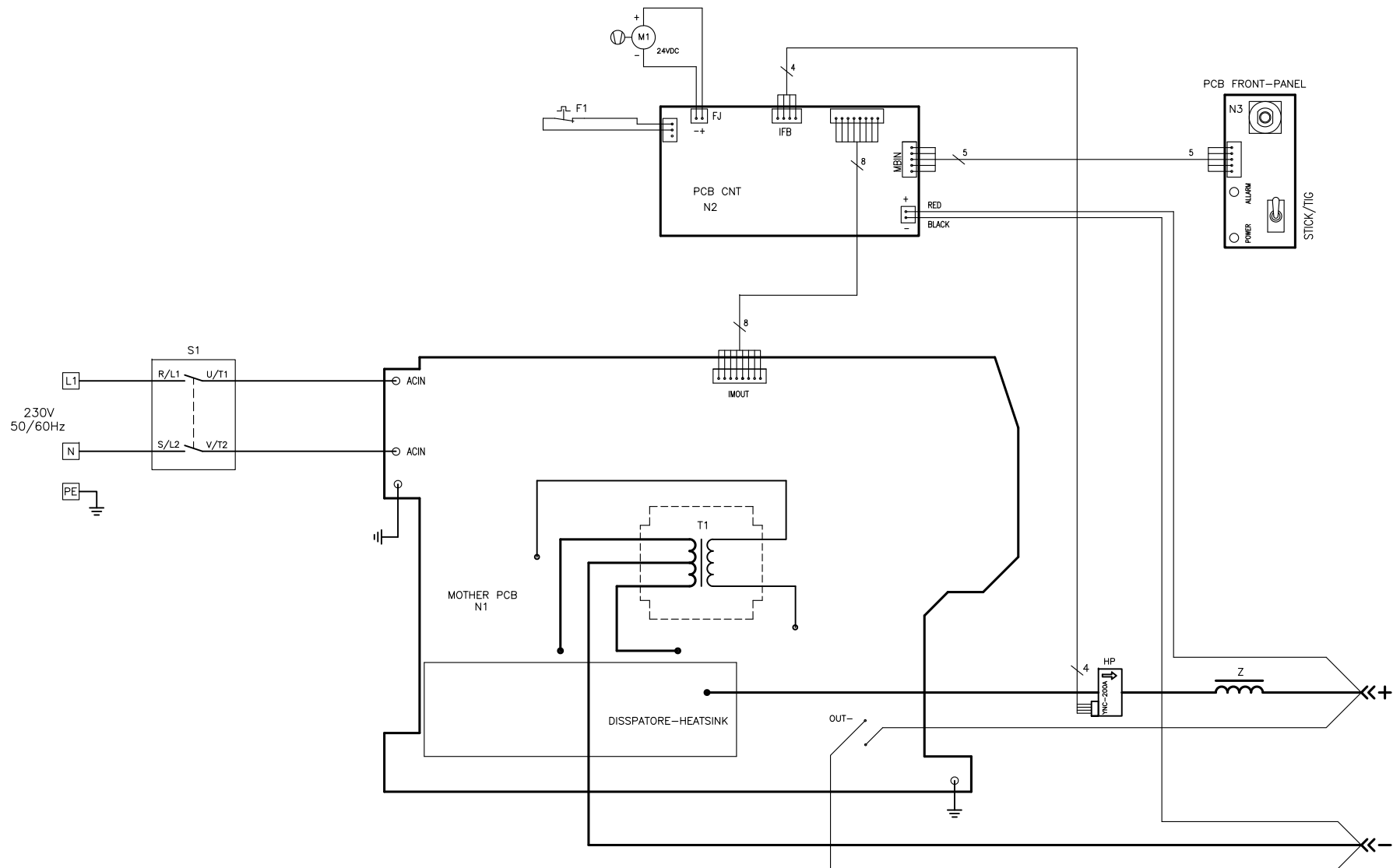

F1	THERMOSTAT	THERMOSTAT	THERMOSTAT	TERMOSTAT	TERMOSTATO
M1	FAN	VENTILATOR	VENTILATEUR	VENTILADOR	VENTILATORE
N1-N3	P.C. BOARD	ELEKTRONIK-PLATTE	FICHE ELECTRONIQUE	CIRCUITO ELECTRONICO	SCHEDA ELETTRONICA
HP	HALL PROBE	STROMSONDE	SONDE DE COURANT	SONDA HALL	SONDA DI CORRENTE
S1	ON - OFF	ON - OFF	ON - OFF	INTERRUPTOR ON - OFF	ON - OFF
T1	TRANSFORMER	TRANSFORMATOR	TRANSFORMATEUR	TRANSFORMADOR	TRASFORMATORE
Z	CHOKE	IMPEDANZ	IMPEDANCE	IMPEDANCIA	IMPEDENZA

Denominazione

GALILEO 219

Codice

S9805101