

# LISTA RICAMBI - SPARE PARTS LIST - LISTA PIEZAS DE REPUESTO



TYPE OF EQUIPMENT

MODEL

**WELDING INVERTER**

**FOX 180**

**230V**

REF AP	PAGE No. 1 of 2	CODE	99820009	WIRING DIAGRAM	S9820009	PARTS DRAWING	E9820008	DATE	11/02/2013
--------	-----------------	------	----------	----------------	----------	---------------	----------	------	------------

No.	P/N	DESCRIZIONE ARTICOLO	ITEM DESCRIPTION	DESCRIPCIÓN DEL ARTÍCULO	QTY
01	21690226	CHIUSURA A SLITTA A FILO	SLIDE CLIP		1
02	33705703 3020	SPORTELO SX FOX 170/190 ROSSO	LEFT DOOR FOX 170/190 RED		1
03	21800069	VOLANTINO X ASPO MINI D.36 CON DADO M10	HAND WHEEL		1
04	33800043	MOLLA GREZ.EST.14X1,8X4,5SP.L=15,5 SPIAN	SPRING		1
05	21690715	ASPO MINI MOBILE X ROCCHETTI D.16-50	MINI SPOOL HOLDER RETAINING RING		1
06	55211014	PERNO ASPO MINI M10 L=86 ZN.NER.33810141	SPOOL SHAFT		1
07	21690714	ASPO MINI FISSO X ROCCHETTI D.16-50	FIXED SPOOL HOLDER		1
08	22900001	ELETTROVALVOLA 4W 230V 50HZ 1/8"FF	GAS SOLENOID VALVE 4W 230V 50HZ 1/8"FF		1
09	22910004	RACCORDO PORTATUBO D.6 1/8"M	HOSE TAIL D.6 1/8"M		1
10	22735375	SCHEDA REGOLAZ. ESTERNA BBT-SLOPE X FOX	SLOPE EXTERNAL REGULATION PCB		1
11	21690737	MANOPOLA M1924 A PRESSIONE X ALBERI D.6	HANDLE		2
12	21800067	POMELLO D.25 CON BOCCOLA FILETTATA M8	KNOB WITH THREADED BUSHING		2
13	04600412	KIT BASETTA GAS-NO GAS PER FOX	KIT GAS/NO GAS CHANGE BOARD		1
14	33720242 9005	DIVISORIO FOX 180 NERO	DIVIDING PANEL BLACK		1
15	04600145	MOTORE D.37 + PIGNONE	MOTOR D.37 + PINION		1
16	44400016	MOTORIDUT.PL.NERO ANONIMO D.37 RUL.06-08	BLACK WIRE FEEDER D.37 ROL.06-08		1
17	77650305	TARGA POLICARBONATO X FOX 180 HELVI	CONTROL PANEL		1
18	04600332	MANOPOLA D.32 X POTENZ. ROSSA + INDICE	RED KNOB D.32 FOR POTENTIOM. + POINTER		2
19	23005492	CANNETTA GUIDAFILO D.2X5 L=87 RIBASSATA	WIRE GUIDE CAPILLARY TUBE		1
20	23005353	ATTACCO MINIEURO PUNG.L=34 +CANNET.	MINIEURO CONNECTION		1
21	22100002	PRESA DINSE FISSA 25MMQ TBEM25 CX30	FEMALE DINSE PLUG 25SQMM CX30		2
22	21690700B	GUSCIO ANTERIORE 2 DINSE + FORO AT.EURO	FRONT TRIM 2 DINSES + EURO PLUG HOLE		1
23	22735364	SCHEDA FRONTALE FOX 180	FRONT PCB		1
24	33700365 9005	FONDO FOX 170 NERO	BOTTOM PANEL BLACK		1
25	22735359	MODULO INVERTER 160A - MIG 170/180	MODULE INVERTER 160A (C) MIG 170/180		1
26	22200047	INT.BIPOLARE NERO NO LUMINOSO C/PROTEZ.	BIPOLAR BLACK SWITCH W/PROTECTION		1
27	04600234	PRESSACAVO X CAVO D.10+VITE AUTOF.	CABLE CLAMP D.10 + SCREW		1
28	20220022	CAVO PVC 3X2,5 MT.2,5 SPINA SHUCO	INPUT CABLE 3X2,5 M 2,5 WITH SHUKO PLUG		1
29	21690701A	GUSCIO POSTERIORE FOX 170 INT.CON PROT.	REAR PANEL		1
30	21600060	CINGHIA FERMA CAVO X FOX 170 L=250 H=15	SECURING CABLE BELT		1
31	21600059	MANIGLIA CURVA FOX 170-190 CON GRADINO	CURVED HANDLE WITH STEP		1
32	33705702 3020	MANTELLO DX FOX 170 ROSSO	RIGHT PANEL FOX 170 RED		1
33	21690225	CERNIERA PER SPORTELO IN PLASTICA 20X30	PLASTIC HINGE FOR ACCESS PANEL 20X30		2

**PROPRIETA' ESCLUSIVA & CONFIDENZIALE:** questo documento contiene informazioni riservate di proprieta esclusiva di HELVI S.p.A. e non puo essere duplicato o inviato a parti terze o usato per altri scopi senza il previo consenso scritto di HELVI S.p.A.

**PROPRIETARY & CONFIDENTIAL:** this document contains proprietary and confidential information owned by HELVI S.p.A. and may not be duplicated, communicated to other parties or used for any purpose without express written permission of HELVI S.p.A.

**PROPIEDAD EXCLUSIVA Y RESERVA:** este documento contiene informaciones reservadas de propiedad exclusiva de HELVI S.p.A. Copia, distribución a terceros y/o utilizzo en cualquier forma sin el permiso expreso por escrito de HELVI S.p.A. están prohibidos.

HELVI S.p.A. si riserva il diritto di modificare qualsiasi informazione qui sopra senza preavviso a seguito di possibili migliorie ai propri prodotti. Questo documento, le informazioni qui riportate e/o allegate sono soggetti alle condizioni generali di vendita in vigore con Voi.

Due to constant improvements HELVI S.p.A. reserves the right to amend any of the above without prior notice. This document, the reported and/or enclosed information are subject to the trading terms and conditions in force with you.

A causa de mejoras en sus productos HELVI S.p.A. se reserva el derecho de modificar cualquier información en este documento sin previo aviso. Este documento, las informaciones referidas y/o adjuntas están sujetos a las condiciones generales de venta vigentes con Uds.



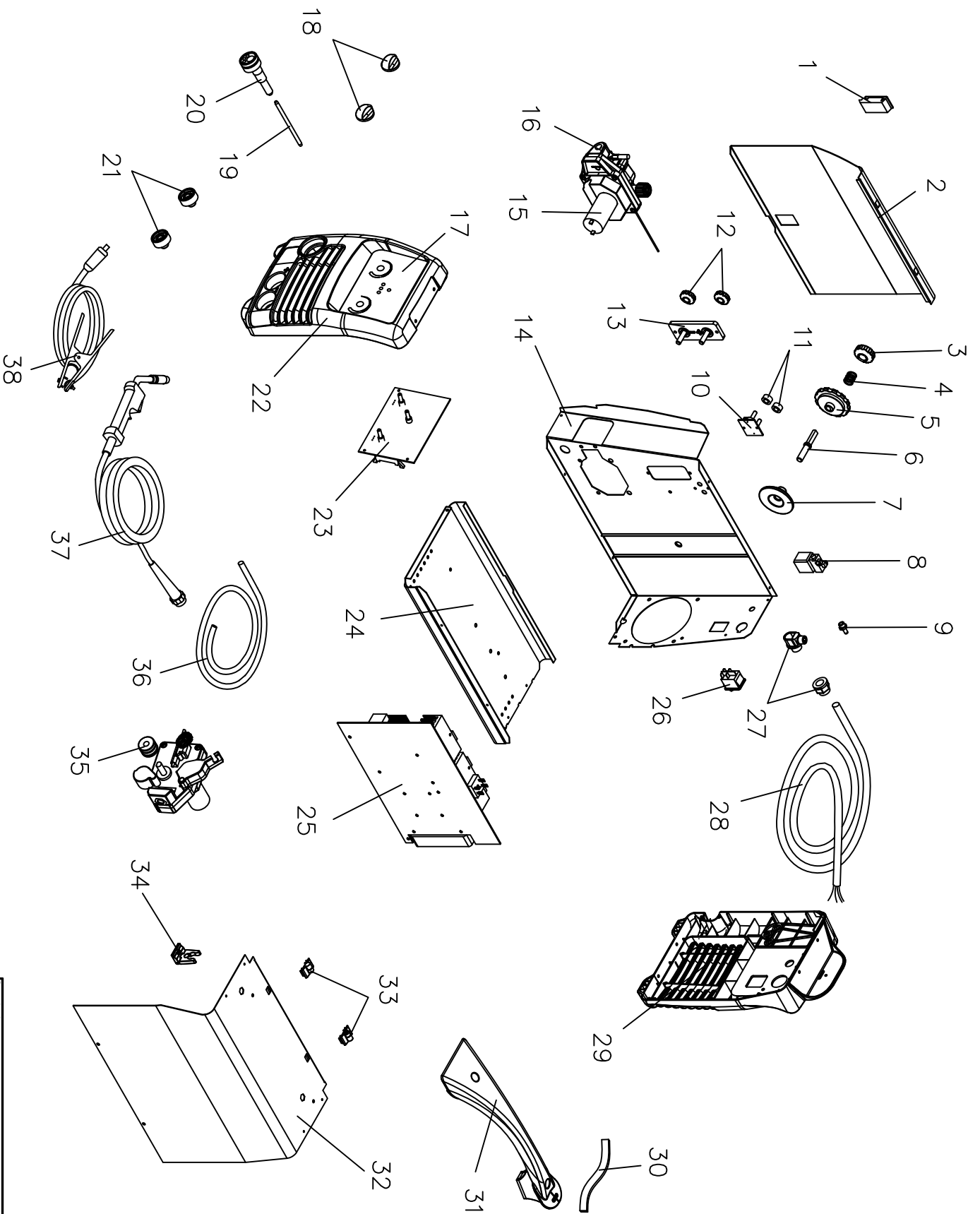

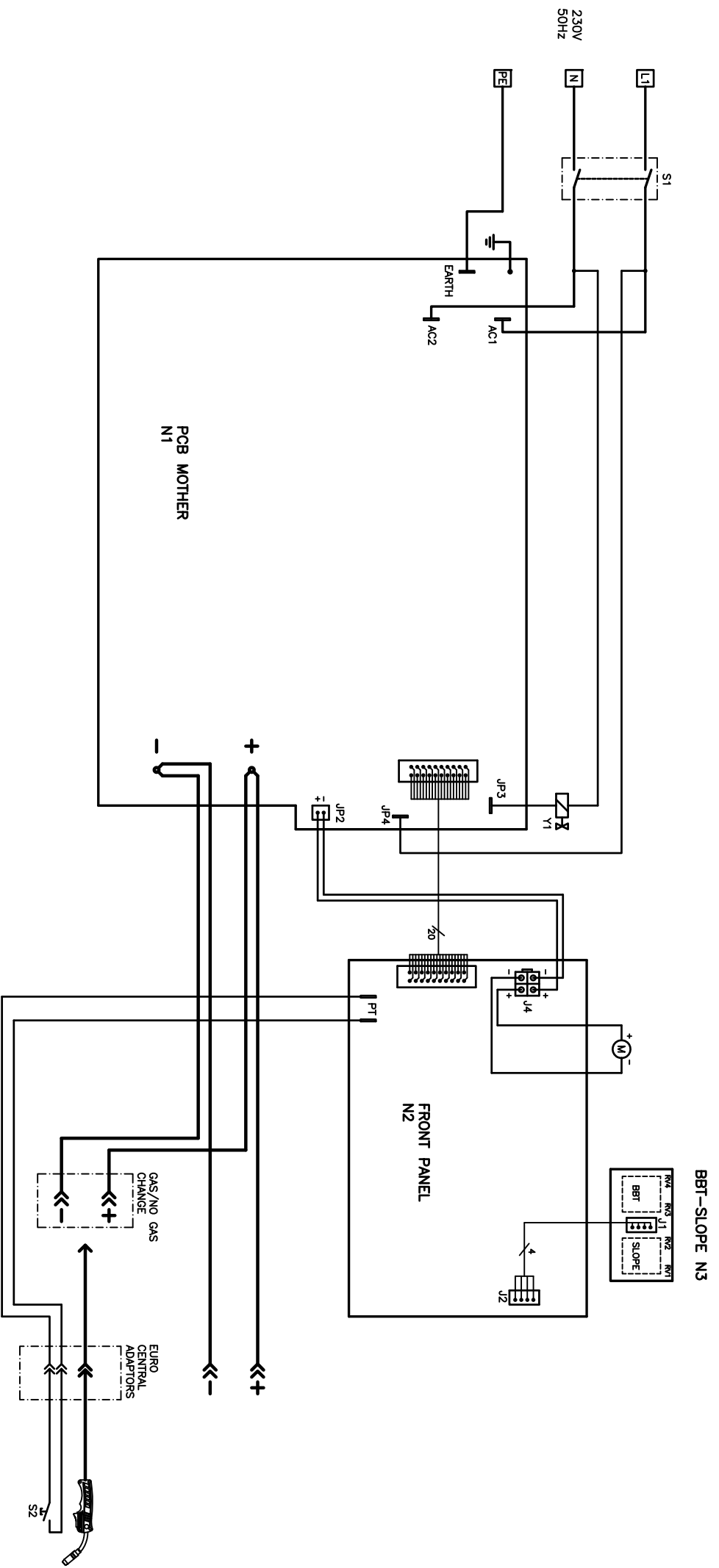

Y1	SOLENOID VALVE	ELEKTROVENTIL	ELETRUVANNE	ELECTROVALVULA	ELETRVALVOLA
M	WIRE FEEDING MOTOR	DRAHTVORSCHUB MOTOR	MOTEUR D'ENTRAINEMENT DU FIL	EQUIPO ARRASTRA HILO	MOTORE TRAINA FILO
N1-N3	P.C. BOARD	ELEKTRONIK-PLATTE	FICHE ELECTRONIQUE	CIRCUITO ELECTRONICO	SCHEDA ELETRONICA
S1	ON - OFF	ON - OFF	ON - OFF	INTERRUPTOR ON - OFF	ON - OFF
S2	TORCH TRIGGER	BRENNER SCHALTER	BOUTON TORCHE	PUSADOR DE LA ANTORCHA	PULSANTE TORCIA