

Denomination

MASTER 292T

Date

31/03/09

Part Number

E9205024



PROPRIETARY & CONFIDENTIAL: this document contains proprietary and confidential information owned by HELVI S.p.A. and may not be duplicated, communicated to other parties or used for any purpose without express written permission of HELVI S.p.A.
 Due to constant improvements HELVI S.p.A. reserves the right to amend any of the above without prior notice.

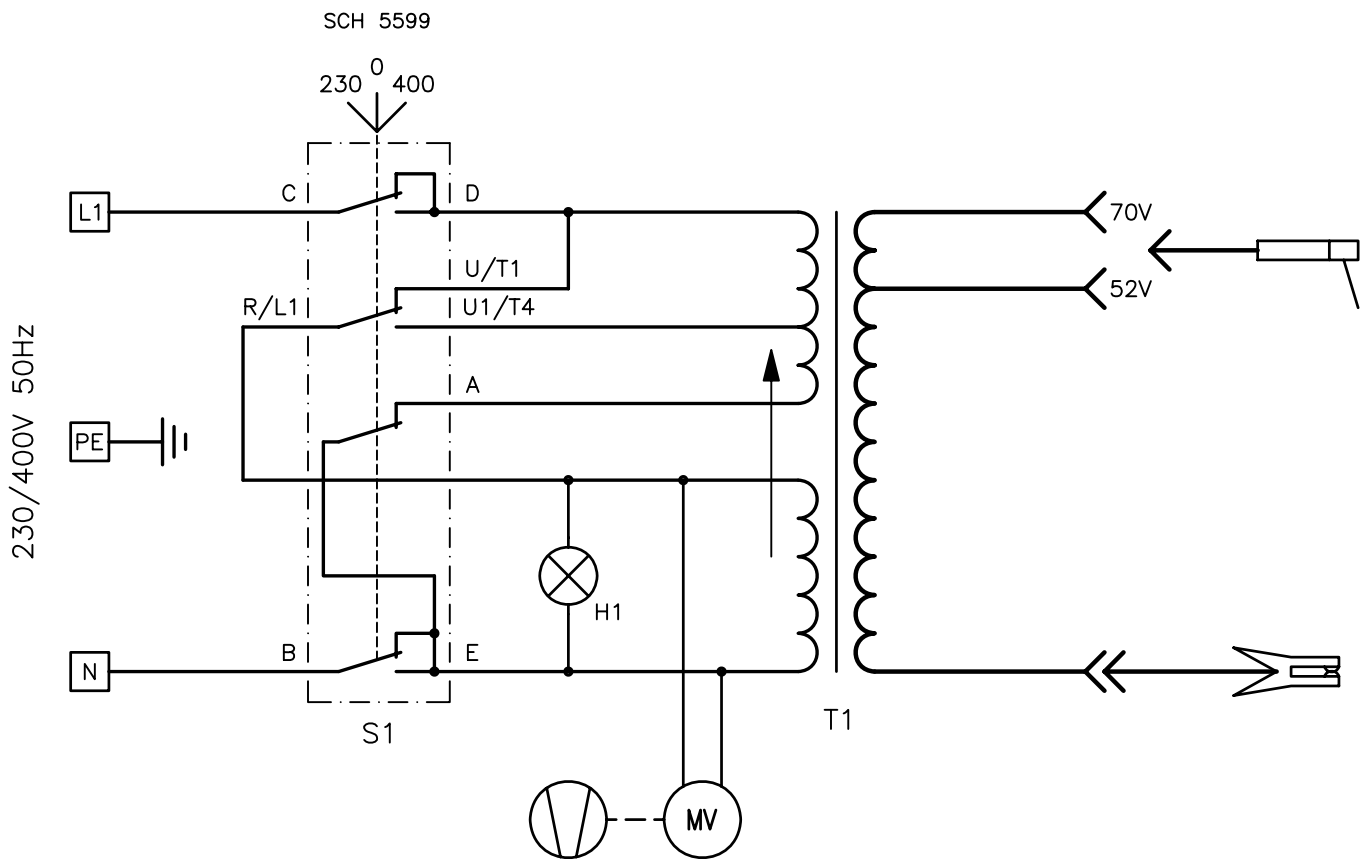

Denomination	MASTER 272	Date	31.03.09	Part Number	S9205010
--------------	------------	------	----------	-------------	----------



PROPRIETARY & CONFIDENTIAL: this document contains proprietary and confidential information owned by HELVI S.p.A. and may not be duplicated, communicated to other parties or used for any purpose without express written permission of HELVI S.p.A. Due to constant improvements HELVI S.p.A. reserves the right to amend any of the above without prior notice.