

# LISTA RICAMBI - SPARE PARTS LIST - LISTA PIEZAS DE REPUESTO



TYPE OF EQUIPMENT

MODEL

**MIG GENERATOR**

**UNIMIG 318 230/400V**

REF AP	PAGE No. 1 of 2	CODE	99415041	WIRING DIAGRAM	S9425151	PARTS DRAWING	E9425053	DATE	31/08/2012
--------	-----------------	------	----------	----------------	----------	---------------	----------	------	------------

No.	P/N	DESCRIZIONE ARTICOLO	ITEM DESCRIPTION	DESCRIPCIÓN DEL ARTÍCULO	QTY
01	21600050	MANIGLIA SX MIG308 TUBO/D25	LEFT HANDLE - HOSE D.25	MANIJA IZQUIERDA - TUBO D.25	1
02	33725107 9005	MANICO MIG 308 M.N. TUBO D.25 L=288 NERO	HANDLE HOSE D.25 L=288 BLACK	MANIJA TUBO D.25 L=288NEGRO	1
03	21690566	PROFILO SUPERIORE MIG308	UPPER PROFILE	PERFIL SUPERIOR	1
04	22205047	COMMUTATORE 20 A SCH 6411 7 POSIZIONI	SWITCH 20 A SCH 6411 7 POSITIONS	CONMUTADOR 20 A SCH 6411 7 POSICIONES	1
05	77650160	TARGA FRONTALE UNIMIG 318	FRONT PLATE UNIMIG 318	ETIQUETA FRONTAL UNIMIG 318	1
06	22205034	COMMUTATORE 20 A CM 33	SWITCH 20A CM 33 3 POSITIONS	CONMUTADOR 20 A CM 33 3 POSICIONES	1
07	21600049	MANIGLIA DX MIG308 TUBO/D25	RIGHT HANDLE MIG308 HOSED.25	MANIJA DERECHA MIG308 TUBO D.25	1
08	33705588R3003	COPERCHIO MIG 318 M.N. ROSSO RAG	RED COVER PANEL MIG 318	PANEL DE COBERTURA ROJO	1
09	33620203	DIVISORIO MIG 318 M.N.	INTERNAL PANEL MIG 318	PANEL INTERNO MIG 318	1
10	22220018	FUSIBILE IN VETRO 6X30 T 4A 250V	FUSE 4A 6X30 T 4A 250V	FUSIBLE 6X30 T 4A 250V	2
11	22220043	PORTAFUSIBILE MOD. M-1003SI/1DS 6,3X32	FUSE HOLDER M-1003SI/1DS 6,3X32	PORTAFUSIBILE	2
12	30905040	STUOIA PORTAOGGETTI 3X270X665 MIG 318	MAT FOR TOOLS 3X270X665 MIG 318	GOMA PARA UTILES 3X270X665 MIG 318	1
13	22225040	CONTATTORE CU-40 24V	CONTACTOR CU-40 24V	CONTACTOR CU-40 24V	1
14	21605011	PRESSACAVO C/GHIERA "STEAB" X FORO D.30	CABLE CLAMP HOLE D.30	PRENSA CABLE	1
15	21070001	GOLFARO MASCHIO M12 ZINCATO	LIFTING-EYE	SOPORTE CHASIS	2
16	21690587	ANGOLARE POSTERIORE SX MIG 308	BACK LEFT ANGULAR	ANGULAR POSTERIOR IZQUIERDO	1
16	21690588	ANGOLARE POSTERIORE DX MIG 308	BACK RIGHT ANGULAR	ANGULAR POSTERIOR DERECHO	1
17	33740249 9005	STAFFA FISS.BOMBOLA MIG 308-318 NERO	GAS BOTTLE HOLDING BRACKET MIG308-318	SOPORTE BOTELLA GAS MIG 308-318 NEGRO	1
18	22105003	CUSTODIA DA INCASSO CNE-06-I+FRUTTO FEM.	MULTIPLE CONNECTING OUTLET CASE (GROOVE)	CONEXION PROLONGACION (HEMBRA)	1
19	22100003	SPINOTTO DINSE VOLANTE 50MMQ TSK50 CX22	DINSE PLUG 50SQMM CX22	CONECTOR MACHO AEREO DE 50QMM CX22	1
21	21690250	VETRINO ROSSO X STRUMENTO DIGITALE 35X80	RED GLASS FOR DIGITAL INSTRUMENT	VIDRIO ROJO PARA INSTRUMENTO DIGITALE	2
22	22710165	STRUM.DIG. MEGADIGIT SMD 400A/60MV X FOD	DIGITAL INSTRUMENT SMD 400A/60MV	INSTR. DIGIT.MEGADIGIT SMD 400A/60MV FOD	1
23	33705587R3003	FIANCATINA SINISTRA MIG 318 M.N. ROSSO R	RED LEFT SIDE PANEL MIG318	PANEL LATERAL IZQUIERDO ROJO MIG318	1
24	22610042	LAMPADA SPIA VERDE D.16 380V SD16	GREEN PILOT LAMP D.16 380V SD16	LUZ PILOTO VERDE D.16 380V SD16	1
25	33705585R3003	FIANCATA SINISTRA MIG 318 M.N. ROSSO RAG	RED LEFT PANEL MIG318	PANLE LATERAL IZQUIERDO ROJO MIG318	1
26	21690371	MANOPOLA ROSSA X COM.PERNO 5 MM B-G1470R	RED SWITCH KNOB	POMO ROJO PARA CONMUTADOR	1
26	21690378	MANOPOLA NERA X COM.PERNO 5 MM B-G1470N	BLACK KNOB FOR SWITCH	POMO PARA CONMUTADOR NEGRO	2
27	22205009	COMMUTATORE 12 A ON-OFF	SWITCH 12 A ON-OFF	CONMUTADOR 12 A 2 POSICIONES	1
28	33705586R3003	FIANCATINA DESTRA MIG 318 M.N. ROSSO RAG	RED RIGHT PANEL MIG318	PANEL LATERAL DERECHO ROJO MIG318	1
29	22610040	LAMPADA SPIA ARANCIO D.16 24V SD16	ORANGE PILOT LAMP D.16 24V SD16	LUZ PILOTO COLOR NARANJA D.16 24V SD16	1
30	33705584R3003	FIANCATA DESTRA MIG 318 M.N. ROSSO RAG.	RED RIGHT PANEL MIG318	PANEL LATERAL DERECHO ROJO MIG318	1
31	20220072	CAVO NEOPRENE 4X4 M 4 SGUAINATO	INPUT CABLE 4X4 M4	CABLE DE ALIMENTACION 4X4 M4	1
32	43210142	CAVO DI MASSA 35 MMQ MT.3 CIN.500/DN50	EARTH CABLE 35 SQMM 3M W/CLAMP 500/DN50	CABLE DE MASA	1

**PROPRIETA' ESCLUSIVA & CONFIDENZIALE:** questo documento contiene informazioni riservate di proprieta esclusiva di HELVI S.p.A. e non puo essere duplicato o inviato a parti terze o usato per altri scopi senza il previo consenso scritto di HELVI S.p.A.

**PROPRIETARY & CONFIDENTIAL:** this document contains proprietary and confidential information owned by HELVI S.p.A. and may not be duplicated, communicated to other parties or used for any purpose without express written permission of HELVI S.p.A.

**PROPIEDAD EXCLUSIVA Y RESERVA:** este documento contiene informaciones reservadas de propiedad exclusiva de HELVI S.p.A. Copia, distribución a terceros y/o utilizzo en cualquier forma sin el permiso expreso por escrito de HELVI S.p.A. están prohibidos.

HELVI S.p.A. si riserva il diritto di modificare qualsiasi informazione qui sopra senza preavviso a seguito di possibili migliorie ai propri prodotti. Questo documento, le informazioni qui riportate e/o allegate sono soggetti alle condizioni generali di vendita in vigore con Voi.

Due to constant improvements HELVI S.p.A. reserves the right to amend any of the above without prior notice. This document, the reported and/or enclosed information are subject to the trading terms and conditions in force with you.

A causa de mejoras en sus productos HELVI S.p.A. se reserva el derecho de modificar cualquier información en este documento sin previo aviso. Este documento, las informaciones referidas y/o adjuntas están sujetos a las condiciones generales de venta vigentes con Uds.



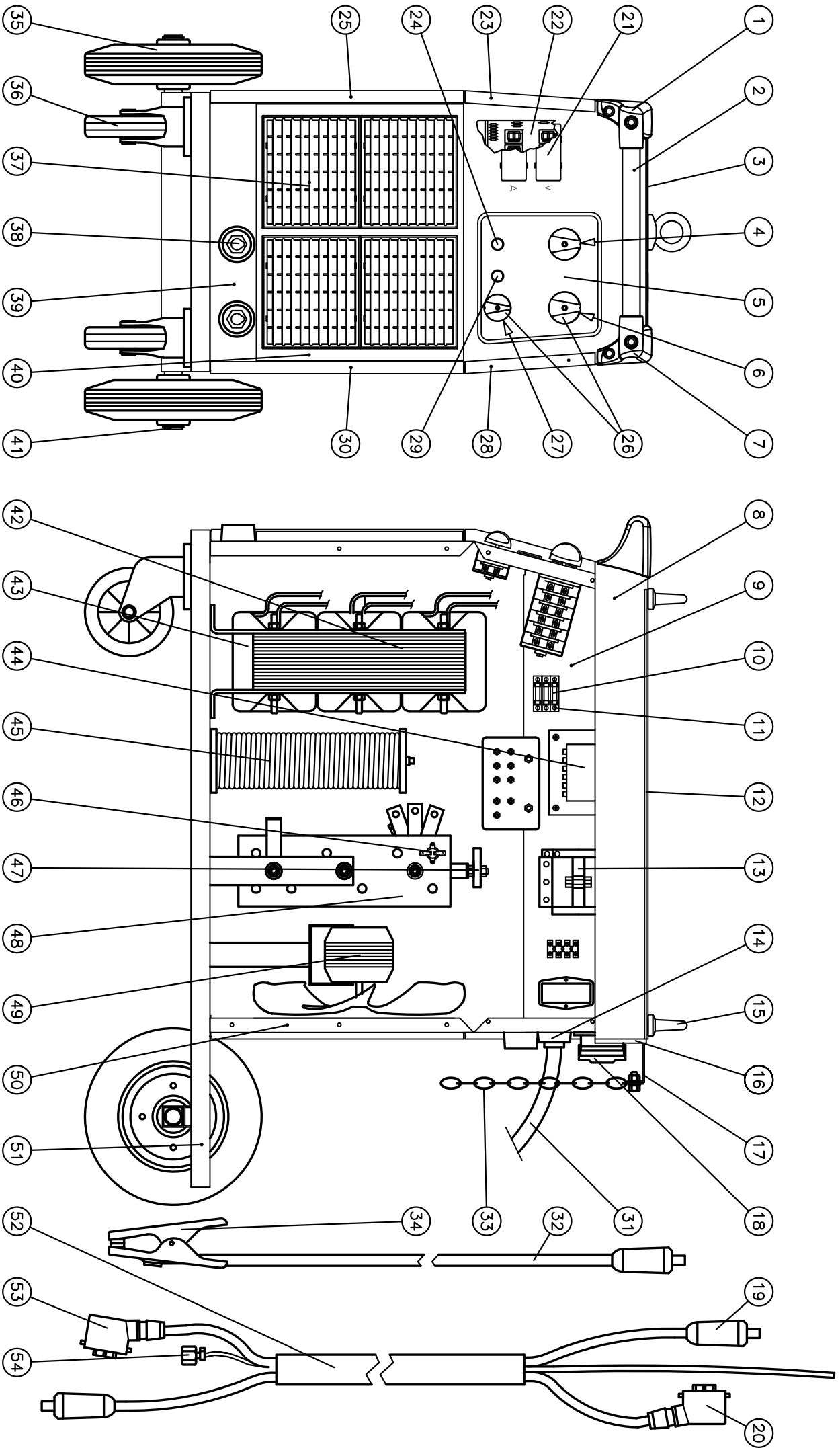

Denominazione

**UNIMIG 318 - 418 TECH**

Codice

**E9425053**



Questo disegno non può essere riprodotto, né ceduto a terzi senza nostro espresso consenso.

Materiali	Codice Mat. Prima	Disegnato	Scala
Dim.	Peso Kg.	Visto	Data
			22-02-10

POSITION	1	2	3	4	5	6	7
RL1	X	X	X	X	X	X	X
RL2	X	X	X	X	X	X	X
RL3	X	X	X	X	X	X	X

POSITION	1	2	3	4	5	6	7
RL1	X	X	X	X	X	X	X
RL2	X	X	X	X	X	X	X
RL3	X	X	X	X	X	X	X

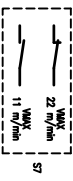
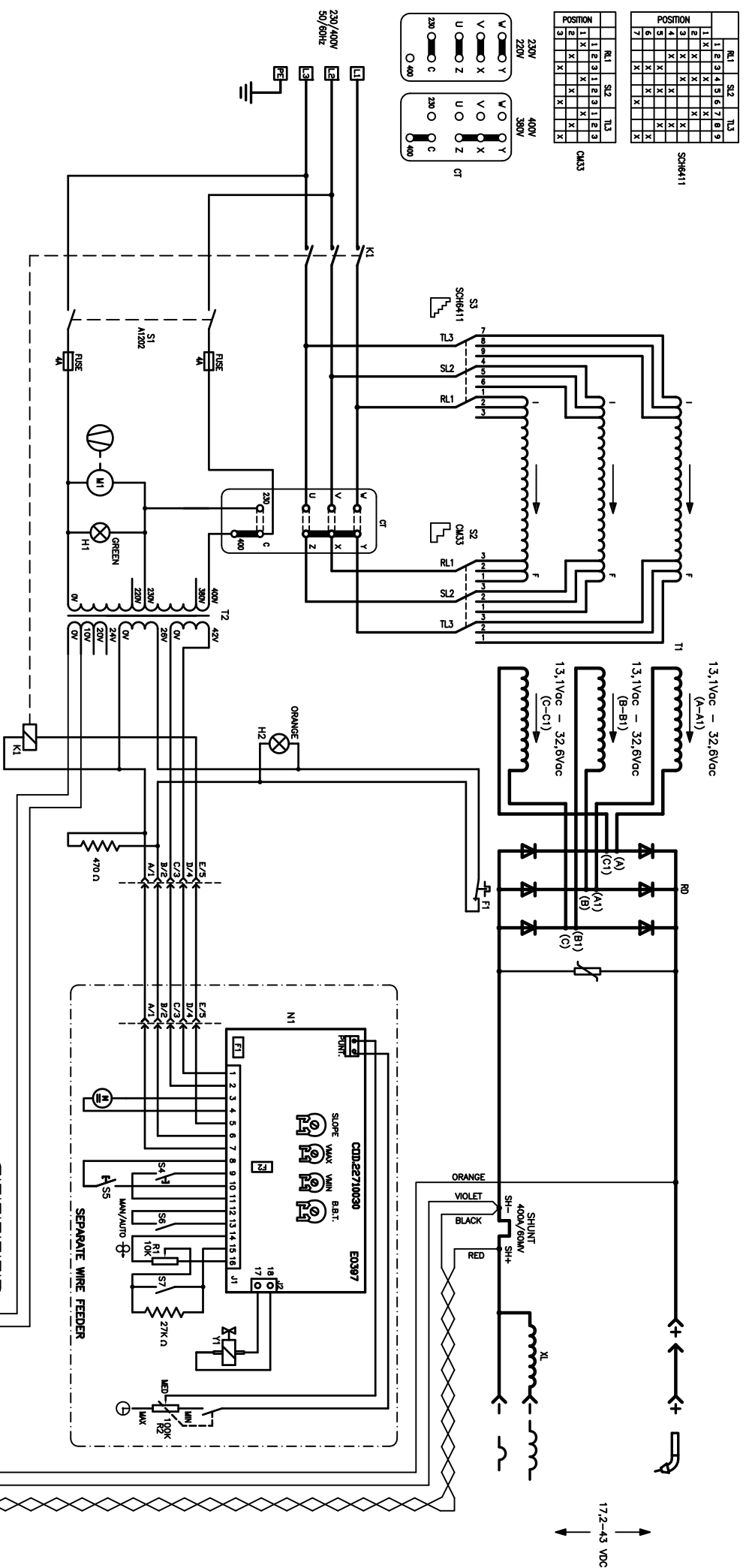
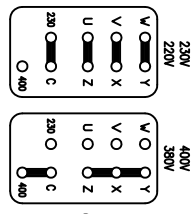

F1	THERMOSTAT	THERMOSTAT	THERMOSTAT
H1	POWER ON PILOT LAMP	NETZKONTROLLLAMPE	LAMPA DA PILOT
H2	THERMOSTAT	THERMOSTATLAMPE	LAMPA SECURITE THERMOSTAT
K1	RELAY	RELAIS	TELETRUCCIONE
Y1	SOLENOID VALVE	ELEKTROVENTIL	ELETTROVALVOLA
XL	CHOKE	IMPEDANZ	IMPEDENZA
M	WIRE FEEDING MOTOR	DRÄHTVORSCHUB MOTOR	MOTORE TRAMA FILO
M1	FAN	VENTILATOR	VENTILATORE
N1	P.C. BOARD	ELEKTRONIK-PLATTE	SCHEMA ELETTRONICA
R1	WIRE FEEDING SPEED	DRÄHTVORSCHUB REGULIERUNG	REGOLAZIONE VELOCITA FILO
RD	RECTIFIER	GLEICHRICHTER	PONTE RADDRIZZATORE

S1	ON - OFF	ON - OFF	ON - OFF
S2-S3	SWITCH	UMSCHALTER	COMMUTATEUR
S4	TORCH TRIGGER	BRÄNNER AUSLÖSER	PUSANTE
S5	WIRE FEEDING BUTTON	DRÄHTVORSCHUB SCHALTER	BOUCON DU MOTORISANT
S6	MANUAL-AUTOMATIC SWITCH	HAND-AUTOMATIK SCHALTER	INTERRUPTEUR MANUEL-AUTOMATIQUE
T1	TRANSFORMER	TRANSFORMATOR	TRANSFORMATEUR
T2	AUXILIARY TRANSFORMER	HILFSTRANSFORMATOR	TRANSFORMATEUR AUXILIAIRE

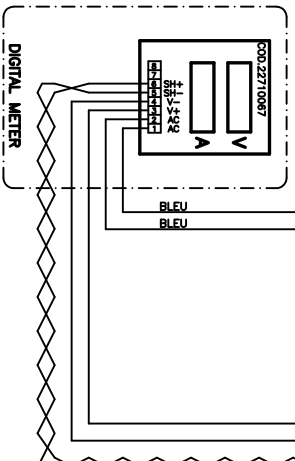

**Denominazione**  
**SCHEMA EL. UNIMIG 318 HELVI TECH 230/400V**  
**Codice S9425151**

Questo disegno non può essere riprodotto, né ceduto a terzi senza nostro espresso consenso.

Dim.	Materiale	Codice Mat. Prima	Disegnato	Scala
Peso Kg.			Visto	Data 10-05-10



# LISTA RICAMBI - SPARE PARTS LIST - LISTA PIEZAS DE REPUESTO



TYPE OF EQUIPMENT

MODEL

## WIRE FEEDER T4

REF FM	PAGE No. 1 of 2	CODE	99420048	WIRING DIAGRAM	S9420024	PARTS DRAWING	E9420053	DATE	03/03/2011
--------	-----------------	------	----------	----------------	----------	---------------	----------	------	------------

No.	P/N	DESCRIZIONE ARTICOLO	ITEM DESCRIPTION	DESCRIPCIÓN DEL ARTÍCULO	QTY
01	26086015	POTENZ. 100K CON INT. PIN DRITTI C/OCCHIEL	POTENTIOMETER 100K WITH SWITCH		1
02	26086023	POTENZIOMETRO 10K LIN. C/OCCHELLI	POTENTIOMETER WX110 B10K LIN. L=10MM		1
03	22710030	SCHEDA DI REGOLAZIONE E0397	P.C. BOARD E0397		1
04	33705596R3003	COPERCHIO CARR.HELVI INCL.LUNGO ROSSO R	COVER PANEL		1
05	33720192R7016	DIVISORIO CARR.HELVI INCL.LUNGO GRIGIO R	INTERNAL PANEL		1
06	33715156R7016	RETRO CARR.HELVI INCL.LUNGO GRIGIO RAG	BACK PANEL		1
07	33710517R7016	FRONTALE CARR.HELVI INCL.LUNGO GRIGIO R	FRONT PANEL		1
08	77650166	TARGA FRONTALE TRAINAFILO T4	FRONT ADHESIVE PLATE		1
09	21690549	MANOPOLA D.33 (ABS ROSSO - GOMMA NERA)	KNOB D.33 (RED ABS - BLACK RUBBER)		2
10	33705594R3003	MANTELLO DX CAR.HELVI INCL.LUNGO ROSSO R	RIGHT SIDE COVER PANEL		1
11	22105002	CUSTODIA DA INCASSO CNE-06-I+FRUTTO MAS.	MULTIPLE CONNECTING OUTLET CASE (TONGUE)		1
12	21690162	.CERNIERA PER SPORTELLO 36X39 =>21690585	.PLASTIC HINGE FOR ACCESS PANEL		2
13	04600275	KIT ASPO HELVI C/GHIERA X ROCCHETTI D.50	SPOOL HOLDER D.50		1
14	33725104 9005	MANICO TRAINAFILO TUBO D.20 L=290 NERO	HANDLE - TUBE D.20 L=290 BLACK		1
15	21600031	MANIGLIA CURVA PER TUBO TONDO D.20	HANDLE SUPPORT		2
16	22200020	DEVIATORE UNIPOLARE A SALD.3A A1-ROSSO	SWITCH		1
17	22200014	INTERRUTTORE UNIPOL.A LEVETTA S1F-1 FEME	MANUAL/AUTOMATIC SWITCH		1
18	22200016	PULSANTE UNIPOL. A LEVETTA S1F-1TC FEME	SWITCH S1F-1TC FEME		1
19	21625039	RUOTA D. 75 GOMMA + SUPP.GIREV.PERNO M12	WHEEL D.75		4
20	22810009	MOTORE 42V 5000 GIRI/MIN D.78 CODE100303	WIRE FEEDING MOTOR 42V D.78		1
21	22900002	ELETTROVALVOLA 4W 24V 50HZ 1/8"FF	GAS SOLENOID VALVE 4W 24V 50HZ 1/8"FF		1
22	21890026	PIATTO X GIOSTRA T.N. CARRELLO TRAINAFI.	PIVOTING TOP OF WIRE FEEDER		1
23	33700249R7016	FONDO CARRELLINO HELVI INCLIN. GRIGIO R.	BOTTOM PANEL		1
24	22100004	PRESA DINSE FISSA 50 MMQ TBE35-50 CX31	DINSE SOCKET 50SQMM CX31		1
25	22910013	ATTACCO MAS.3/8"GAS,PORTATUBO D.7 C/DADO	GAS CONNECTOR		1
26	21690003	PROTEZIONE COPRIFORO ATT.TORCIA BINZEL	BINZEL TORCH CONNECTION GROMMET		1
27	23005350	ATTACCO EURO PUNG.L=32 + CANNETTA(C)=>49	EURO CONNECTOR		1
29	21690454	CORNICE FRONTALE TRAINAFILO INCLINATO	WIRE FEEDER FRONT FRAME		1
30	33705595R3003	SPORTELLO SX CAR.HELVI INC.LUNGO ROSSO R	LEFT SIDE ACCESS PANEL		1
31	21690226	CHIUSURA A SLITTA A FILO	SLIDE CLIP		1
32	44410026	MOTORID.AL.ECON. D78 42V 70W 4RUL. 1-1,2	ALUM.WIRE FEEDER D78 42V 70W 4RUL. 1-1,2		1
33	33805003	RULLINO TRAINAF.D.30 0,6-0,8MM MOT.AL.2R	WIRE FEED ROLL 0,6-0,8MM AL.MOTOR 2R		2
33	33805005	RULLINO TRAINAF.D.30 1,0-1,2MM MOT.AL.2R	WIRE FEED ROLL 1,0-1,2MM AL.MOTOR 2R		2

**PROPRIETA' ESCLUSIVA & CONFIDENZIALE:** questo documento contiene informazioni riservate di proprietà esclusiva di HELVI S.p.A. e non può essere duplicato o inviato a parti terze o usato per altri scopi senza il previo consenso scritto di HELVI S.p.A.

**PROPRIETARY & CONFIDENTIAL:** this document contains proprietary and confidential information owned by HELVI S.p.A. and may not be duplicated, communicated to other parties or used for any purpose without express written permission of HELVI S.p.A.

**PROPIEDAD EXCLUSIVA Y RESERVA:** este documento contiene informaciones reservadas de propiedad exclusiva de HELVI S.p.A. Copia, distribución a terceros y/o utilizzo en cualquier forma sin el permiso expreso por escrito de HELVI S.p.A. están prohibidos.

HELVI S.p.A. si riserva il diritto di modificare qualsiasi informazione qui sopra senza preavviso a seguito di possibili migliorie ai propri prodotti. Questo documento, le informazioni qui riportate e/o allegate sono soggetti alle condizioni generali di vendita in vigore con Voi.

Due to constant improvements HELVI S.p.A. reserves the right to amend any of the above without prior notice. This document, the reported and/or enclosed information are subject to the trading terms and conditions in force with you.

A causa de mejoras en sus productos HELVI S.p.A. se reserva el derecho de modificar cualquier información en este documento sin previo aviso. Este documento, las informaciones referidas y/o adjuntas están sujetos a las condiciones generales de venta vigentes con Uds.

LISTA RICAMBI - SPARE PARTS LIST - LISTA PIEZAS DE REPUESTO

TYPE OF EQUIPMENT

MODEL



WIRE FEEDER T4

Table with 4 columns: REF FM, PAGE No. 2 of 2, CODE 99420048, WIRING DIAGRAM S9420024, PARTS DRAWING E9420053, DATE 03/03/2011

Main table with columns: No., P/N, DESCRIZIONE ARTICOLO, ITEM DESCRIPTION, DESCRIPCIÓN DEL ARTÍCULO, QTY. Contains rows for parts 33, 34, 35, 36.

PROPRIETARY & CONFIDENTIAL: this document contains proprietary and confidential information owned by HELVI S.p.A. and may not be duplicated, communicated to other parties or used for any purpose without express written permission of HELVI S.p.A.

PROPIEDAD EXCLUSIVA Y RESERVA: este documento contiene informaciones reservadas de propiedad exclusiva de HELVI S.p.A. Copia, distribución a terceros y/o uso en cualquier forma sin el permiso expreso por escrito de HELVI S.p.A. están prohibidos.

HELVI S.p.A. si riserva il diritto di modificare qualsiasi informazione qui sopra senza preavviso a seguito di possibili miglie e ai propri prodotti. Questo documento, le informazioni qui riportate e/o allegate sono soggetti alle condizioni generali di vendita in vigore con Voi.

Due to constant improvements HELVI S.p.A. reserves the right to amend any of the above without prior notice. This document, the reported and/or enclosed information are subject to the trading terms and conditions in force with you.

A causa de mejoras en sus productos HELVI S.p.A. se reserva el derecho de modificar cualquier información en este documento sin previo aviso. Este documento, las informaciones referidas y/o adjuntas están sujetos a las condiciones generales de venta vigentes con Uds.

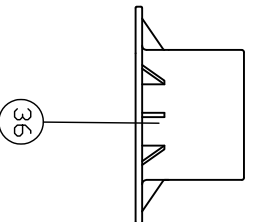
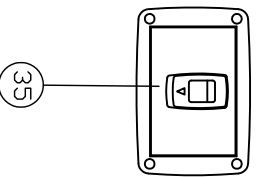
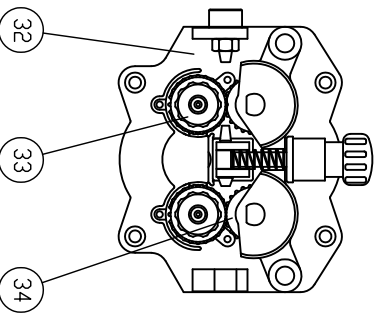
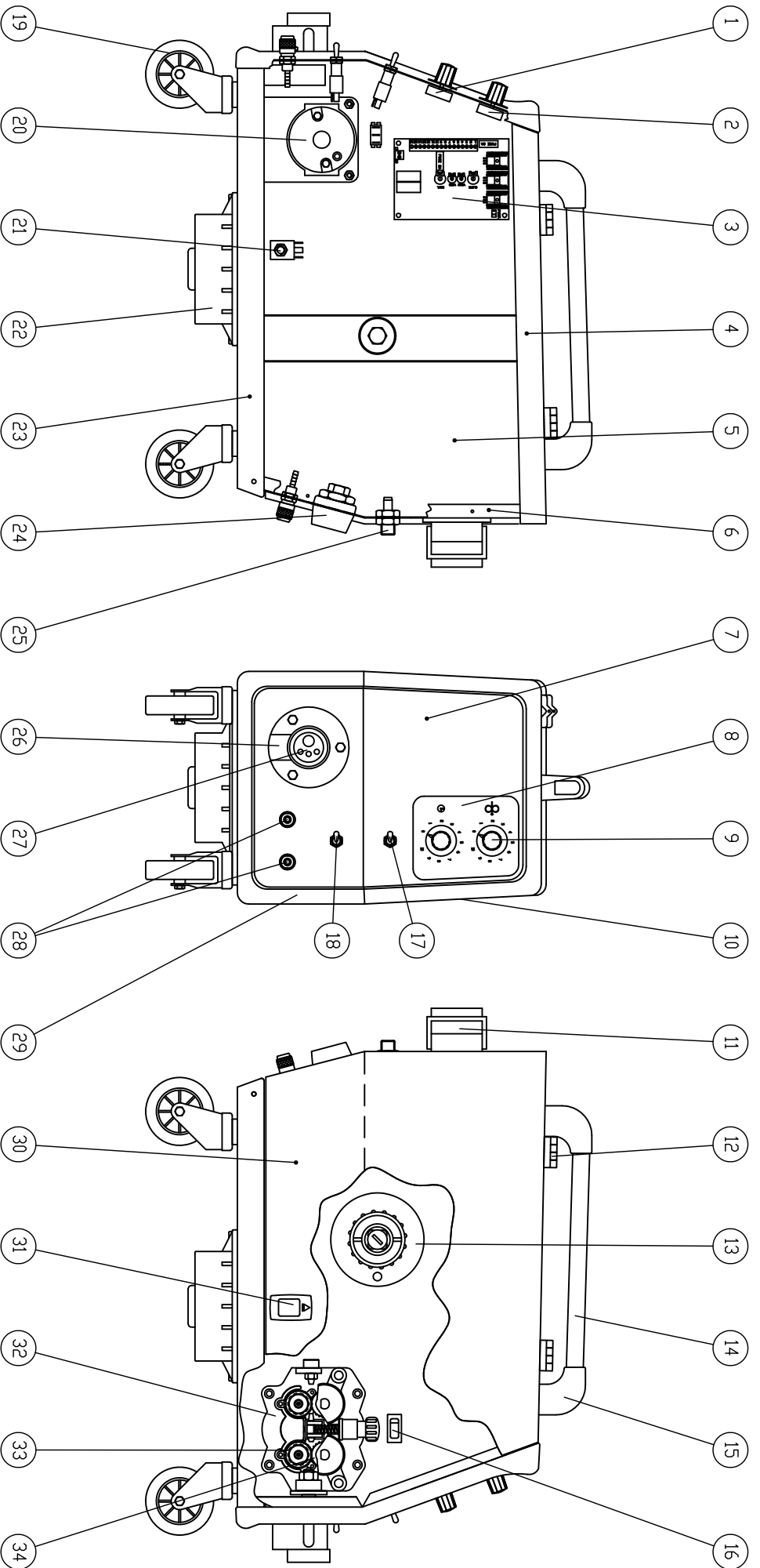

Denominazione

TRAINALLO T4

Codice

E9420053



Questo disegno non può essere riprodotto, né ceduto a terzi senza nostro espresso consenso.

Materiale

Codice Mat. Prima

Disegnato

Scala

Dim.

Peso Kg.

Visto

Data

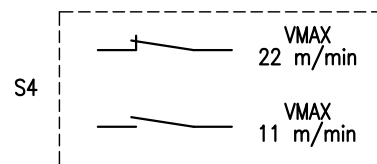
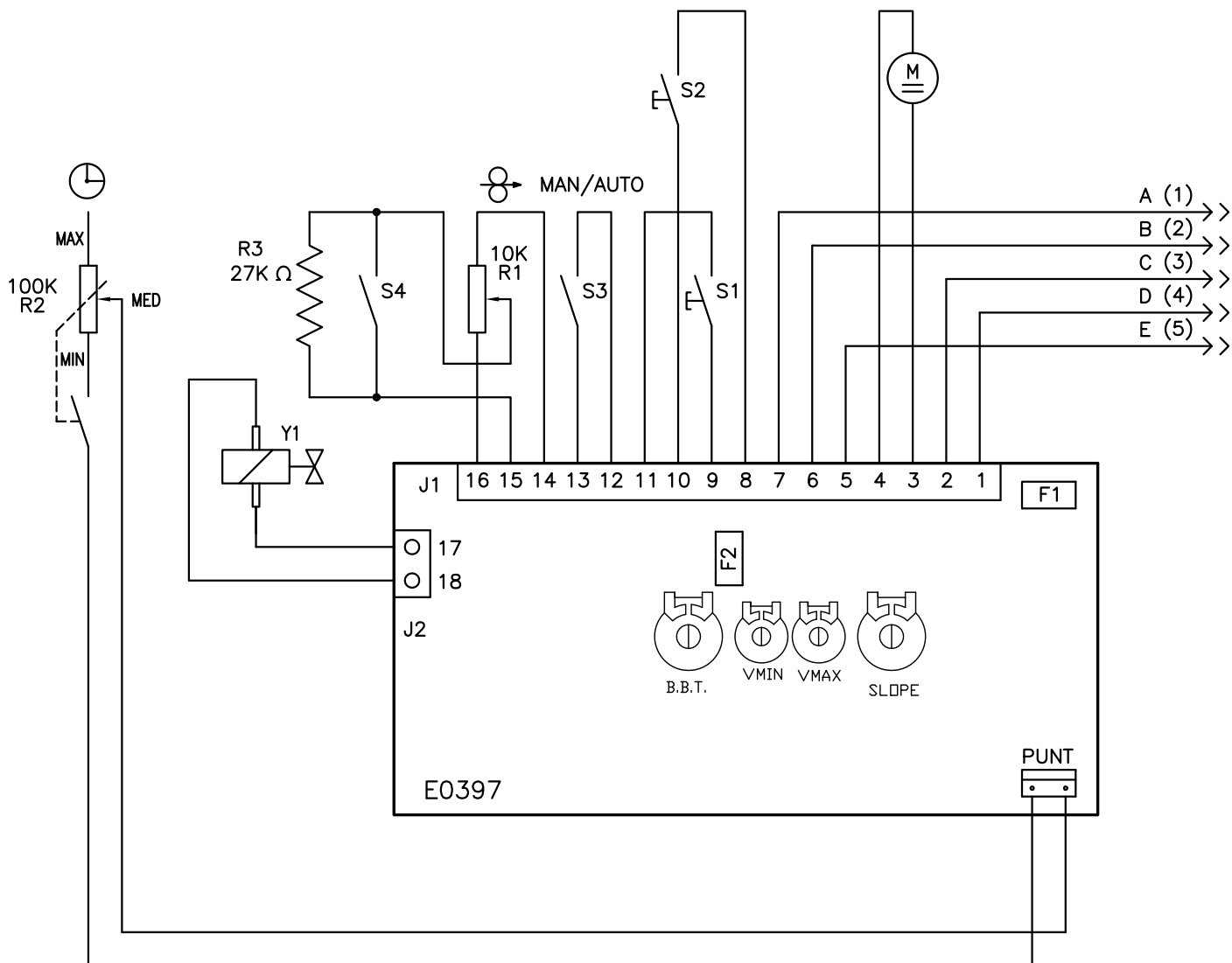

Y1	SOLENOID VALVE	ELEKTROVENTJL	ELETROVANNE	ELETTRORVALVOLA
M	WIRE FEEDING MOTOR	DRAHTVORSCHUB MOTOR	MOTEUR D'ENTRAINEMENT DU FIL	MOTORE TRAINA FILO
S1	TORCH PUSH BUTTON	BRENNER SCHALTER	BOUTON TORCHE	PULSANTE TORCIA
S2	WIRE FEEDING BUTTON	DRAHTVORSCHUB SCHALTER	BOUTON DU MOTEUR DU FIL	PULSANTE AVANZAMENTO FILO
S3	MANUAL - AUTOMATIC SWITCH	HAND - AUTOMATIK SCHALTER	INTERRUPTEUR MANUEL - AUTOMATIQUE	INTERRUTTORE MANUALE - AUTOMATICO
R1	WIRE FEEDING SPEED	DRAHTVORSCHUB - REGELUNG	REGLAGE DE LA VITESSE DU FIL	REGOLAZIONE VELOCITA' FILO

Denominazione

**TRAINAFILO + AVANZAMENTO FILO**

Codice

**S9420024**



Questo disegno non puo' essere riprodotto, ne' ceduto a terzi senza nostro espresso consenso.

Materiale

Codice Mat. Prima

Disegnato

Scala

Dim.

Peso Kg.

Visto

Data

03-09-09